

# BRONZE KIOSK (EXPO)

## GRAPHIC SUBMISSION GUIDELINES

\*Section A needs to include either the company name or company logo

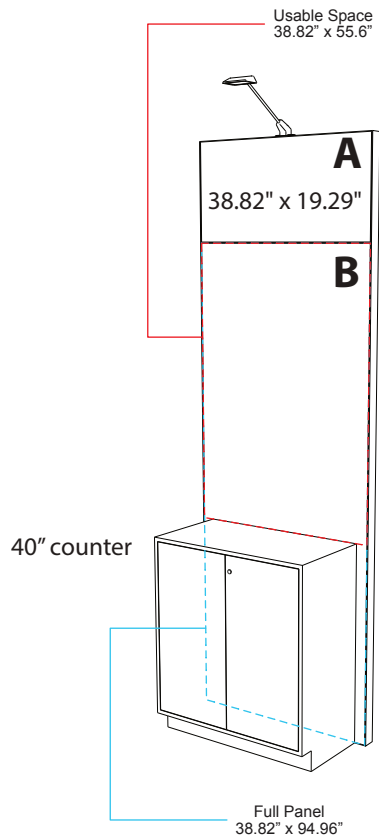

**OPTION 1**  
 No Monitor

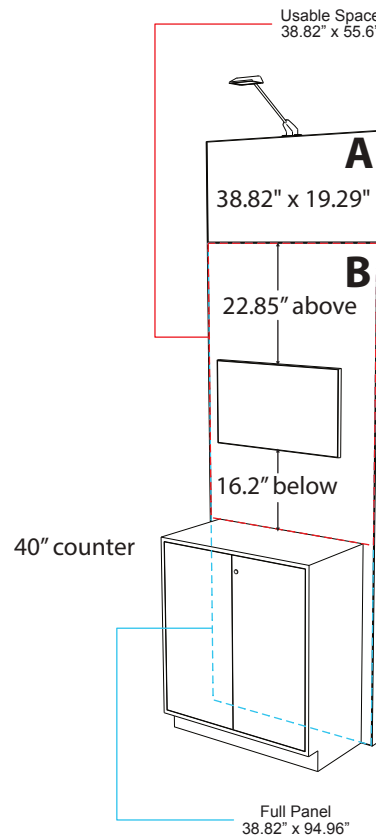

**OPTION 2**  
 Optional 32" Monitor

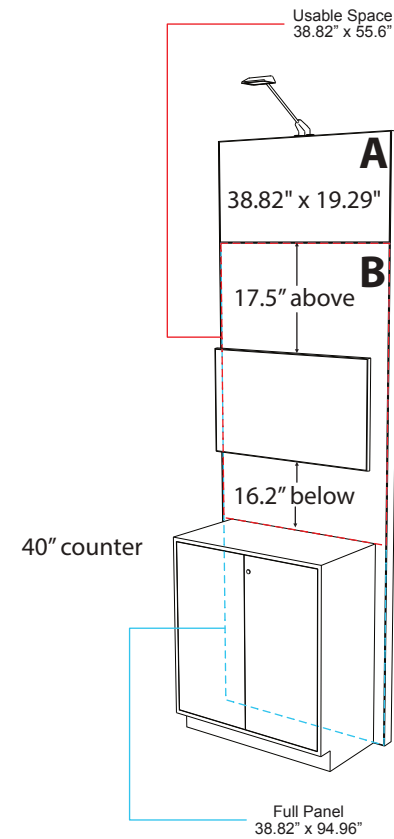

**OPTION 3**  
 Optional 43" Monitor

\*For Panel B – While the visible graphic area is only 38.82" x 55.6", the graphic file for submission must be 38.82" x 94.96"



# Directions North America 2025

Monday, April 7 – Wednesday, April 9, 2025  
Virgin Hotels Las Vegas

## BRONZE KIOSK (EXPO) ORDER FORM

**WILLWORK**  
7500 Exchange Drive,  
Orlando, FL 32809  
774-568-5425

ARTWORK SUBMISSION DEADLINE .....	2/6/2025
ARTWORK APPROVAL DEADLINE (all artwork submitted and approved) .....	2/27/2025
ARTWORK LATE APPROVAL PERIOD (Sponsor incurs 30% rush fee) .....	3/13/2025
Please note: If approved graphics are not received by Thursday, March 13, 2025, your company logo will be printed in lieu of your graphics.	

### Description

#### BRONZE KIOSK (EXPO)\*

\*Includes 2 Graphic Panels (A & B)

**A. Header Panel: 38.82" wide x 19.29" high**

File Name: \_\_\_\_\_

**B. Back Panel: 38.82" wide x 94.96" high\***

File Name: \_\_\_\_\_

**32" Mounted Monitor is Optional**

Rental price is \$320.00 for the 32" monitor and includes the mount and HDMI cable.

**43" Mounted Monitor is Optional**

Rental price is \$400.00 for the 43" monitor and includes the mount and HDMI cable.

*Please email [DirectionsGraphics@willwork.com](mailto:DirectionsGraphics@willwork.com) with tv measurements once a size is chosen*

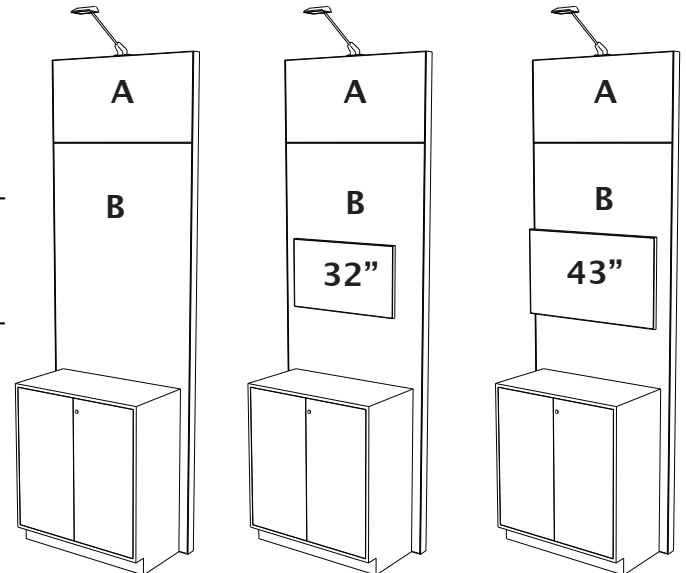

**CIRCLE ONE**

OPTION 1

OPTION 2

OPTION 3

**PLEASE NOTE:**

**AV is NOT included.**

\*For Panel B – While the visible graphic area is only 38.82" x 55.6", the graphic file submission must be 38.82" x 94.96". Please see page 1 for size breakdown.

\*\*Electrical drop will be placed into the demo counter, as shown in the rendering. If you require additional drops, or placement of your drops to be in a location other than the back of your kiosk, please contact the Virgin Hotel. If you need to upgrade your drops, you will be credited for the value of the drops included in your sponsorship package by the electrical services provider.

\*\*\*If hardline Internet is required, please order separately. Please contact the Virgin Hotel.

150 DPI – PRINTABLE PDF OR ILLUSTRATOR FILE – [DirectionsGraphics@willwork.com](mailto:DirectionsGraphics@willwork.com)

**Please print or type information below:**

Contact Name:	Email:
Telephone:	Fax:
Exhibiting Company Name:	Kiosk Number:

**Please Note:** Kiosk is included in your sponsorship package. For monitor rentals and exhibitor orders, a Credit Card must be on file to ensure payment. No Goods or services will be rendered without a credit card accompanying this order. Your preferred method of payment will be used, if other than the credit card on file, to complete this order at the close of the show. Please visit the Willwork Service Desk to finalize your invoice. No adjustment will be made after the close of the show.



# Directions North America 2025

Monday, April 7 – Wednesday, April 9, 2025

Virgin Hotels Las Vegas

## BRONZE EXPO HALL HANGING BANNER ORDER FORM

**WILLWORK**  
7500 Exchange Drive,  
Orlando, FL 32809  
774-568-5425

ARTWORK SUBMISSION DEADLINE .....2/6/2025  
ARTWORK APPROVAL DEADLINE (all artwork submitted and approved) .....2/27/2025  
ARTWORK LATE APPROVAL PERIOD (Sponsor incurs 30% rush fee) .....3/13/2025

Please note: If approved graphics are not received by Thursday, March 13, 2025, your company logo will be printed in lieu of your graphics.

### Description

#### BRONZE EXPO HALL HANGING BANNER\*

**Banner Size 36" wide x 96" high**

File Name: \_\_\_\_\_

**Specifications:**

Full Bleed: 37.25" w x 97.25" t (includes .625" bleed on all four sides.)

Trim: 36" w x 96" t

Live Safe Area: Set all text at least 1" from crop line

**Include Bleed Area and Crop Marks:**

All files must have a 0.625" bleed on each side. Artwork must extend to the full bleed area (37.25" x 97.25"). On your PDF, please include bleed area and show crop marks at 36" x 96".

**Grommets:**

Grommets will be placed approximately 1.5" within the safe area at the top of the banner. Make sure you do not have any crucial text or graphics in areas where the grommets could interfere.

**Pole Pockets:**

A 3" pole pocket will be placed at the bottom of the banner. Some banners may have a 3" pole pocket instead of grommets at the top. Make sure you do not have any crucial text or graphics in areas where the pole pockets could interfere.

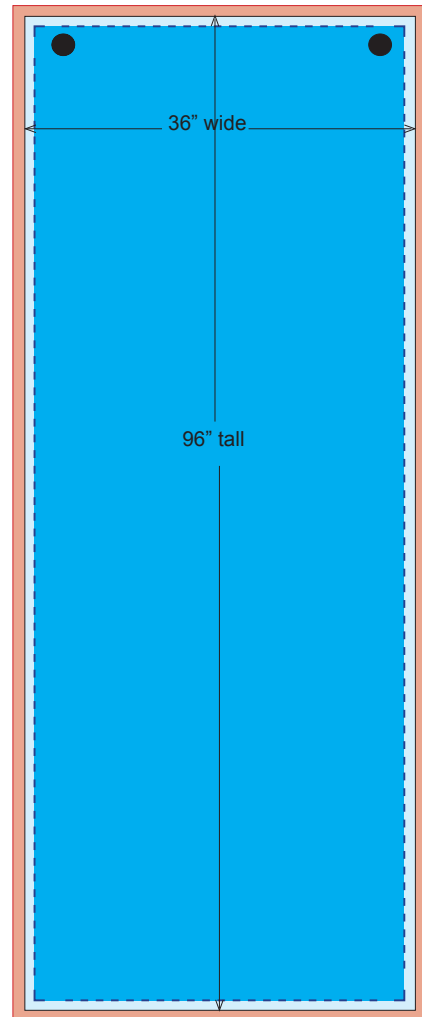

150 DPI – PRINTABLE PDF OR ILLUSTRATOR FILE – DirectionsGraphics@willwork.com

**Please print or type information below:**

Contact Name:	Email:	
Telephone:	Fax:	
Exhibiting Company Name:	Kiosk Number:	

**Please Note:** Kiosk is included in your sponsorship package. For monitor rentals and exhibitor orders, a Credit Card must be on file to ensure payment. No Goods or services will be rendered without a credit card accompanying this order. Your preferred method of payment will be used, if other than the credit card on file, to complete this order at the close of the show. Please visit the Willwork Service Desk to finalize your invoice. No adjustment will be made after the close of the show.