

EXECUTIVE OWNERSHIP TRACK KIOSK (PREMIER)

2M Wide x 9.5' Tall with Seamless SEG Graphics

GRAPHIC SUBMISSION GUIDELINES

*Section A needs to include either the Company name or company logo

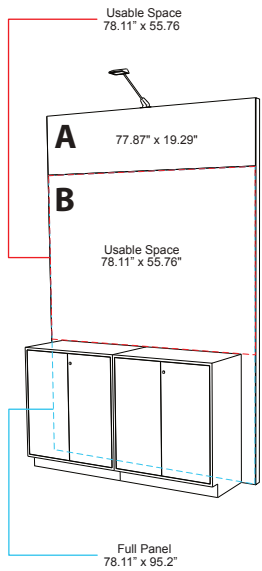

OPTION 1
 No Monitor

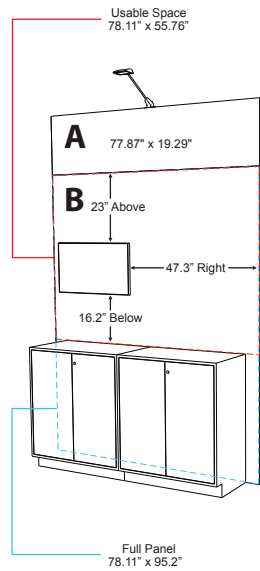

OPTION 2A
 Optional 32" Monitor

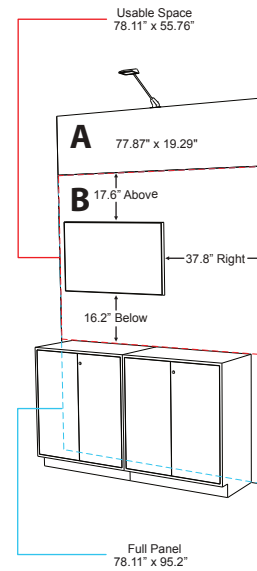

OPTION 2B
 Optional 43" Monitor

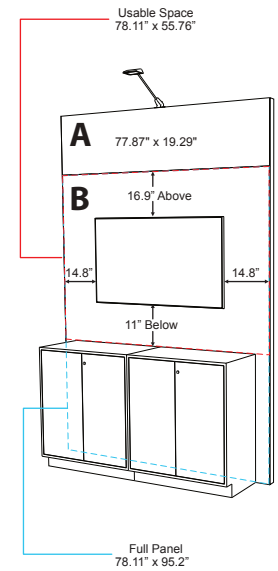

OPTION 3
 Optional 55" Monitor

*For Panel B – While the visible graphic area is only 78.11" x 55.76", the graphic file for submission must be 78.11" x 95.2"



Directions North America 2025

Monday, April 7 – Wednesday, April 9, 2025

Virgin Hotels Las Vegas

WILLWORK
7500 Exchange Drive,
Orlando, FL 32809
774-568-5425

EXECUTIVE OWNERSHIP TRACK KIOSK (PREMIER) ORDER FORM

ARTWORK SUBMISSION DEADLINE	2/6/2025
ARTWORK APPROVAL DEADLINE (all artwork submitted and approved).....	2/27/2025
ARTWORK LATE APPROVAL PERIOD (Sponsor incurs 30% rush fee)	3/13/2025
Please note: If approved graphics are not received by Thursday, March 13, 2025, your company logo will be printed in lieu of your graphics.	

PLEASE SUBMIT TWO ORDER FORMS, ONE FOR EACH KIOSK.

Description

Executive Ownership Track Kiosk (Premier)*

*Includes 2 Graphic Panels (A & B)

A. Header Panel: 77.87" wide x 19.29" high

File Name: _____

B. Back Panel: 78.11" wide x 95.2" high*

File Name: _____

32" Mounted Monitor is Optional

Rental price is \$320.00 for the 32" monitor and includes the mount and HDMI cable.

43" Mounted Monitor is Optional

Rental price is \$400.00 for the 43" monitor and includes the mount and HDMI cable.

55" Mounted Monitor is Optional

Rental price is \$550.00 for the 55" monitor and includes the mount and HDMI cable.

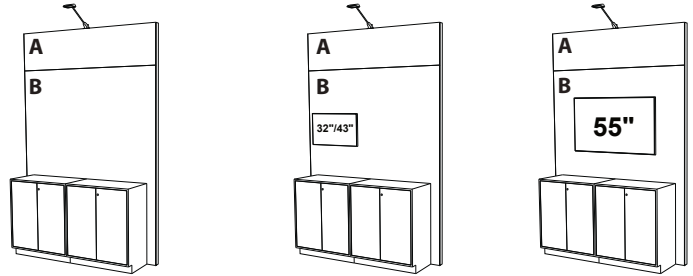

OPTION 1

CIRCLE ONE

OPTION 2A
32" monitor

OPTION 2B
43" monitor

OPTION 3

PLEASE NOTE:

AV is NOT included.

Please email DirectionsGraphics@willwork.com with tv measurements once a size is chosen

*For Panel B – While the visible graphic area is only 78.11" x 55.76", the graphic file for submission must be 78.11" x 95.2". Please see page 1 for size breakdown.

**Electrical drop will be placed into the demo counter, as shown in the rendering. If you require additional drops, or placement of your drops to be in a location other than the back of your kiosk, please contact the Virgin Hotel. If you need to upgrade your drops, you will be credited for the value of the drops included in your sponsorship package by the electrical services provider.

***If hardline Internet is required, please order separately. Please contact the Virgin Hotel.

150 DPI – PRINTABLE PDF OR ILLUSTRATOR FILE – DirectionsGraphics@willwork.com

Please print or type information below:

Contact Name:	Email:
Telephone:	Fax:
Exhibiting Company Name:	Kiosk Number:

Please Note: Kiosk is included in your sponsorship package. For monitor rentals and exhibitor orders, a Credit Card must be on file to ensure payment. No Goods or services will be rendered without a credit card accompanying this order. Your preferred method of payment will be used, if other than the credit card on file, to complete this order at the close of the show. Please visit the Willwork Service Desk to finalize your invoice. No adjustment will be made after the close of the show.

EXECUTIVE OWNERSHIP TRACK KIOSK (EXPO)

GRAPHIC SUBMISSION GUIDELINES

*Section A needs to include either the company name or company logo

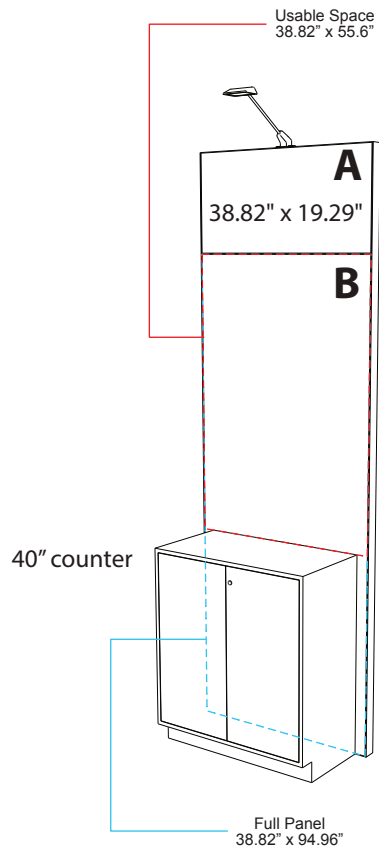

OPTION 1
 No Monitor

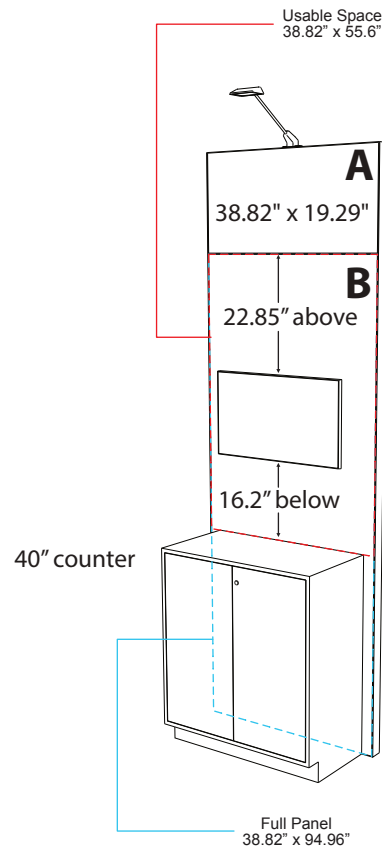

OPTION 2
 Optional 32" Monitor

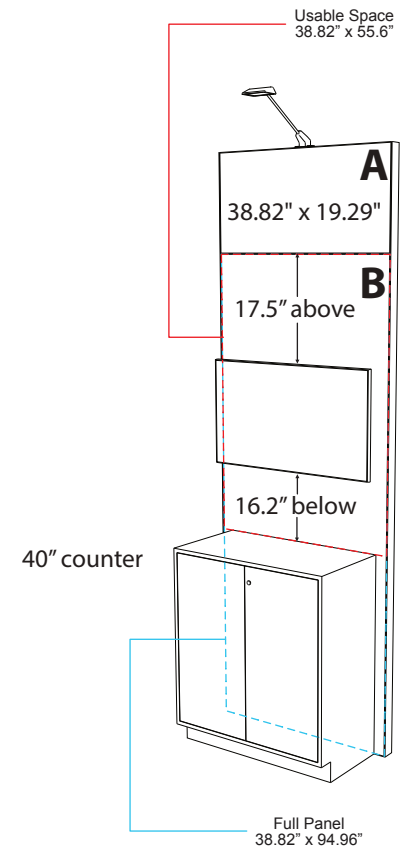

OPTION 3
 Optional 43" Monitor

*For Panel B – While the visible graphic area is only 38.82" x 55.6", the graphic file for submission must be 38.82" x 94.96"



Directions North America 2025

Monday, April 7 – Wednesday, April 9, 2025
Virgin Hotels Las Vegas

EXECUTIVE OWNERSHIP TRACK KIOSK (EXPO) ORDER FORM

WILLWORK
7500 Exchange Drive,
Orlando, FL 32809
774-568-5425

ARTWORK SUBMISSION DEADLINE	2/6/2025
ARTWORK APPROVAL DEADLINE (all artwork submitted and approved)	2/27/2025
ARTWORK LATE APPROVAL PERIOD (Sponsor incurs 30% rush fee)	3/13/2025
Please note: If approved graphics are not received by Thursday, March 13, 2025, your company logo will be printed in lieu of your graphics.	

PLEASE SUBMIT TWO ORDER FORMS, ONE FOR EACH KIOSK.

Description

EXECUTIVE OWNERSHIP TRACK KIOSK (EXPO)*

*Includes 2 Graphic Panels (A & B)

A. Header Panel: 38.82" wide x 19.29" high

File Name: _____

B. Back Panel: 38.82" wide x 94.96" high*

File Name: _____

32" Mounted Monitor is Optional

Rental price is \$320.00 for the 32" monitor and includes the mount and HDMI cable.

43" Mounted Monitor is Optional

Rental price is \$400.00 for the 43" monitor and includes the mount and HDMI cable.

Please email DirectionsGraphics@willwork.com with tv measurements once a size is chosen

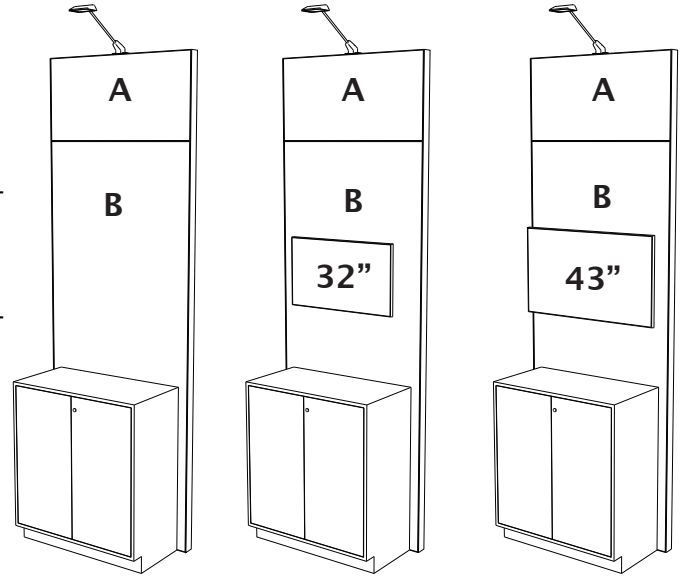

CIRCLE ONE

OPTION 1

OPTION 2

OPTION 3

PLEASE NOTE:

AV is NOT included.

*For Panel B – While the visible graphic area is only 38.82" x 55.6", the graphic file submission must be 38.82" x 94.96". Please see page 1 for size breakdown.

**Electrical drop will be placed into the demo counter, as shown in the rendering. If you require additional drops, or placement of your drops to be in a location other than the back of your kiosk, please contact the Virgin Hotel. If you need to upgrade your drops, you will be credited for the value of the drops included in your sponsorship package by the electrical services provider.

***If hardline Internet is required, please order separately. Please contact the Virgin Hotel.

150 DPI – PRINTABLE PDF OR ILLUSTRATOR FILE – DirectionsGraphics@willwork.com

Please print or type information below:

Contact Name:	Email:
Telephone:	Fax:
Exhibiting Company Name:	Kiosk Number:

Please Note: Kiosk is included in your sponsorship package. For monitor rentals and exhibitor orders, a Credit Card must be on file to ensure payment. No Goods or services will be rendered without a credit card accompanying this order. Your preferred method of payment will be used, if other than the credit card on file, to complete this order at the close of the show. Please visit the Willwork Service Desk to finalize your invoice. No adjustment will be made after the close of the show.