

EXPO EXHIBITOR KIOSK (EXPO)

GRAPHIC SUBMISSION GUIDELINES

*Section A needs to include either the company name or company logo

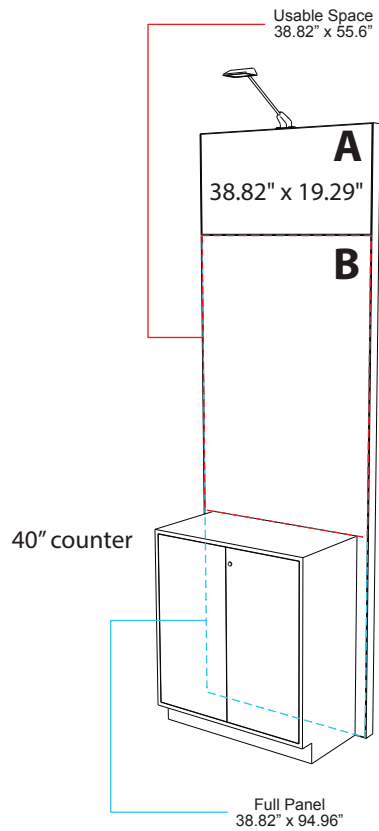

OPTION 1
 No Monitor

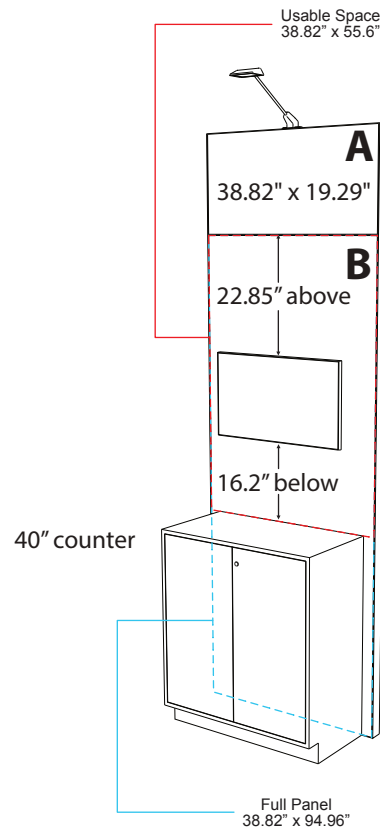

OPTION 2
 Optional 32" Monitor

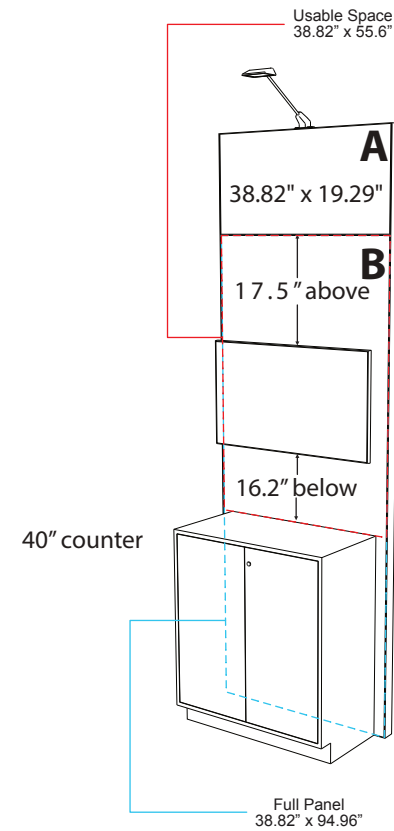

OPTION 3
 Optional 43" Monitor



Directions North America 2025

Monday, April 7 – Wednesday, April 9, 2025

Virgin Hotels Las Vegas

EXPO EXHIBITOR KIOSK (EXPO) ORDER FORM

WILLWORK
7500 Exchange Drive,
Orlando, FL 32809
774-568-5425

ARTWORK SUBMISSION DEADLINE2/6/2025
ARTWORK APPROVAL DEADLINE (all artwork submitted and approved)2/27/2025
ARTWORK LATE APPROVAL PERIOD (Sponsor incurs 30% rush fee)3/13/2025

Please note: If approved graphics are not received by Thursday, March 13, 2025, your company logo will be printed in lieu of your graphics.

Description

EXPO EXHIBITOR KIOSK (EXPO)*

*Includes 2 Graphic Panels (A & B)

A. Header Panel: 38.82" wide x 19.29" high

File Name: _____

B. Back Panel: 38.82" wide x 94.96" high*

File Name: _____

32" Mounted Monitor is Optional

Rental price is \$320.00 for the 32" monitor and includes the mount and HDMI cable.

43" Mounted Monitor is Optional

Rental price is \$400.00 for the 43" monitor and includes the mount and HDMI cable.

Please email DirectionsGraphics@willwork.com with tv measurements once a size is chosen

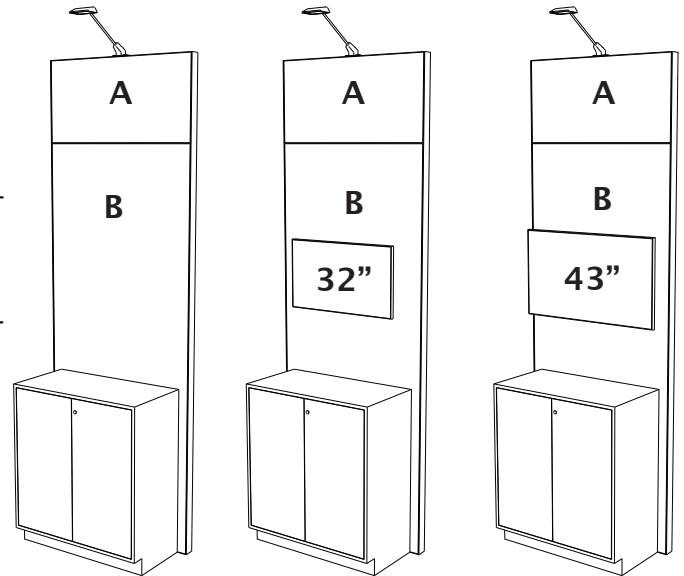

CIRCLE ONE

OPTION 1

OPTION 2

OPTION 3

PLEASE NOTE:

AV is NOT included.

*For Panel B – While the visible graphic area is only 38.82" x 55.6", the graphic file submission must be 38.82" x 94.96". Please see page 1 for size breakdown.

**Electrical drop will be placed into the demo counter, as shown in the rendering. If you require additional drops, or placement of your drops to be in a location other than the back of your kiosk, please contact the Virgin Hotel. If you need to upgrade your drops, you will be credited for the value of the drops included in your sponsorship package by the electrical services provider.

***If hardline Internet is required, please order separately. Please contact the Virgin Hotel.

150 DPI – PRINTABLE PDF OR ILLUSTRATOR FILE – DirectionsGraphics@willwork.com

Please print or type information below:

Contact Name:	Email:
Telephone:	Fax:
Exhibiting Company Name:	Kiosk Number:

Please Note: Kiosk is included in your sponsorship package. For monitor rentals and exhibitor orders, a Credit Card must be on file to ensure payment. No Goods or services will be rendered without a credit card accompanying this order. Your preferred method of payment will be used, if other than the credit card on file, to complete this order at the close of the show. Please visit the Willwork Service Desk to finalize your invoice. No adjustment will be made after the close of the show.